

# Investigating Factors Contributing to Poor Performance in Teaching and Learning of N3 Assembly Drawing: A Case of uMgungundlovu TVET College

Mthokozisi Sakhile Mkhwanazi, \* Philani Brian Mlambo

School of Education, Faculty of Arts and Design, Durban University of Technology, 13 FJ Sithole RD, Imbali Unit 1, Pietermaritzburg, 3201, South Africa

\* Corresponding Author e-mail: [brianmdineka@gmail.com](mailto:brianmdineka@gmail.com)

Received: October 2023; Revised: January 2024; Published: March 2024

## Abstract

Poor performance in Assembly Drawing (AD) has been a significant issue in Engineering Graphics and Design (EGD) in high schools and TVET colleges. This poor performance in AD, which is a crucial component of the EGD exam, leads to students not performing well in Grade 12 and consequently limits their entry into engineering programs in TVET colleges. Consequently, this study aims to investigate the contributing factors to poor performance in the teaching and learning of AD among N3 students. To achieve the objectives of this study, a mixed research approach was employed, and data was collected through semi-structured interviews and the Purdue Spatial Visualization Test (PSVT). A purposive sampling method was used to select four Engineering Drawing (ED) lecturers and 45 N3 Engineering Drawing students to participate in this study. Furthermore, Piaget's perception and imagery theory and Pedagogical Content Knowledge (PCK) were utilized as frameworks underpinning this study. The interview results were analyzed using thematic analysis, while the data from the PSVT was analyzed using the Statistical Package for Social Sciences (SPSS). The findings of this study indicate that N3 students have very low spatial visualization skills, and the negative attitude displayed by both students and lecturers towards the teaching and learning of AD contributes to poor performance in N3 ED. The findings further revealed that the lack of drawing-related teaching qualifications among lecturers also contributes to poor performance in AD. Furthermore, the quantitative findings show that the students achieved a mean score of 16.82, with a standard deviation of 8.389, indicating poor performance on the PSVT test. One limitation of this study is the small number of lecturers interviewed (four), which makes it difficult to generalize the results. Therefore, future studies should include a larger sample size of lecturers. This study recommends that lecturers be hired based on their relevant teaching qualifications and further suggests the use of technology to enhance students' spatial visualization skills and improve their performance in AD.

**Keywords:** Assembly drawing; Engineering graphics and design; TVET; Spatial visualization; Engineering drawing

**How to Cite:** Mlambo, P. B., & Mkhwanazi, M. S. (2024). Investigating Factors Contributing to Poor Performance in Teaching and Learning of N3 Assembly Drawing: A Case of uMgungundlovu TVET College. *Jurnal Penelitian Dan Pengkajian Ilmu Pendidikan: E-Saintika*, 8(1), 102-121. <https://doi.org/10.36312/esaintika.v8i1.1479>



<https://doi.org/10.36312/esaintika.v8i1.1479>

Copyright© 2024, Mlambo & Mkhwanazi

This is an open-access article under the [CC-BY-SA](https://creativecommons.org/licenses/by-sa/4.0/) License.



## INTRODUCTION

Over the past years in South Africa, the pass rates in Matric have been consistently low. This is a cause for concern, as Matric pass rates are indicative of the overall performance of the education sector in South Africa. Low pass rates suggest that students will have difficulty gaining entry into higher education institutions and

will subsequently struggle to compete in the job market. The poor performance in Matric results can be attributed to underachievement in certain key subjects, including Mathematics, Accounting, Physical Sciences, and Economics (DBE, 2011).

Another contributing factor to low Matric results is that students face challenges in mastering specific chapters significantly weighted in the overall exam. For instance, in Engineering Graphics and Design (EGD), students have been observed to struggle with Assembly Drawing (AD), which carries substantial weight in EGD paper 2. AD is of particular importance for learners pursuing a career in mechanical engineering, as it is specifically tailored to this field. As per DBE (2011), AD accounts for over 45 percent of the entire EGD paper. This indicates that if a significant number of learners struggle with AD, the chances of EGD producing satisfactory results are greatly diminished.

Reports indicate that many learners are performing poorly in AD, with various factors contributing to this outcome. According to DBE (2022), numerous candidates faced challenges with AD. Additionally, Sotsaka (2015) noted during his tenure as an EGD advisor that many learners had poor performance in AD. These observations suggest that learners in EGD are encountering difficulties in understanding and effectively performing in AD. This has significant implications for the field of engineering, as many learners who study EGD aspire to become engineers, specifically in mechanical, civil, and electrical engineering. However, due to the poor performance in AD, learners interested in pursuing mechanical engineering face a greater risk of being denied admission to engineering courses.

It is worth noting that the issue of poor AD performance is not unique to South Africa; it also exists in other countries, such as China. A study conducted by Cheng et al. (2018) revealed that students in Chinese universities struggle to grasp the concept of AD. This global crisis calls for immediate intervention to address the problem and prevent further consequences in the field of engineering. The poor performance in Additional Drawing (AD) has been a contributing factor to the overall poor performance of N3 students in Technical Vocational Education and Training (TVET). It is believed that the same students who performed poorly in Engineering Graphics and Design (EGD), specifically AD, are admitted into TVET colleges for Engineering courses, resulting in a continued cycle of poor performance. Badenhorst and Radile (2018) have highlighted that the ongoing issue of poor performance in TVET colleges poses a threat to the future of the students whom these institutions will produce. This sentiment is echoed by Diraso et al. (2013), who describe how poor performance in EGD hampers the aspirations of learners who want to pursue engineering-related courses, as it denies them entry into higher institutions of learning. Diraso et al. (2013) further assert that the inadequate qualifications of teachers contribute to the poor performance in Drawing. According to Sotsaka (2015), another contributing factor to poor performance in AD is a lack of skill in spatial visualization. These factors mentioned above all contribute to the overall poor performance in AD (Ramatsitse et al., 2023). The poor performance in EGD, particularly in AD, is a pressing concern throughout the country, and existing studies do not provide a comprehensive understanding of the factors that contribute to this issue. Therefore, this study aims to investigate the factors that contribute to the poor performance in the teaching and learning of AD at uMgungundlovu N3 TVET college. Given the scarcity of studies conducted in this specific context of TVET colleges, this study will serve as a groundbreaking intervention to address the poor performance in AD and facilitate

greater admission of students into engineering courses. Furthermore, the lack of research conducted in AD in the field of education in general has made this inquiry necessary.

### Purpose and Research Questions

This study aims to investigate the factors contributing to poor performance in the teaching and learning of N3 Assembly Drawing at uMgungundlovu TVET College. The need for this inquiry arises from growing concerns surrounding the inadequate performance in the teaching and learning of AD. The study is guided by the following critical question: What are the factors that contribute to poor performance in the teaching and learning of N3 Assembly Drawing at uMgungundlovu TVET College? The following sub-research questions support this question:

1. RQ1: What is the level of spatial visualization among N3 Engineering Drawing students?
2. RQ2: What teaching methods do lecturers use to teach AD?
3. RQ3: What are the lecturers' views on AD and the students' perception of AD?

### Literature Review

#### *Assembly Drawing in the Context of Engineering Graphics and Design*

The Assembly Drawing, also known as the Mechanical Assembly Drawing, is a section in Engineering Graphics and Design (EGD) that is covered in high school. According to Singh-Pillay and Sotsaka (2016), the Assembly Drawing presents the various parts of a machine that need to be assembled to form a complete mechanical component. Cheng et al. (2018) define the Assembly Drawing as a crucial part of engineering education, teaching students drawing techniques, recognition rules, and methods for creating mechanical drafts. It involves the use of graphics, symbols, words, and figures to express design intentions (T. I. Mtshali & Singh-Pillay, 2023). This chapter accounts for approximately 45% of Paper 2 in the Department of Basic Education (DBE) curriculum (2011), highlighting its significance in EGD. To perform well in Paper 2, students must excel in this chapter.

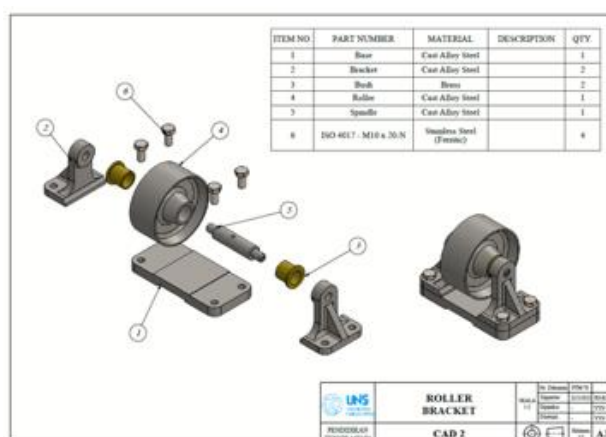

**Figure 1.** Exploded view of AD

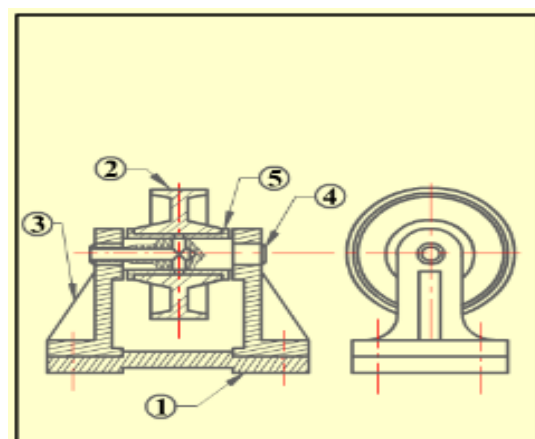

**Figure 2.** Expected answer

Sotsaka (2015) further emphasizes that the Assembly Drawing is the most important chapter in Paper 2. Van Leeuwen and du Plooy (2011) describe the Assembly Drawing as the combination of two or more distinct components, with these multi-component devices forming uniquely designed components that come together

to create a usable whole. Essentially, the Assembly Drawing consists of an exploded view (3D), which students are expected to convert into a sectional view (2D). Figure 1 illustrates an exploded view of an assembly drawing, representing the 3D aspect of the Assembly Drawing. Figure 2 depicts the 2D part of the assembly drawing, which is the task typically assigned to students. In simpler terms, Assembly Drawing involves converting a 3D mechanical component into a 2D sectional view.

### ***Spatial Visualisation in Assembly Drawing***

Assembly Drawing involves the conversion of 3D to 2D, which is a challenging task (Šafhalter et al., 2022). Consequently, many students are not performing well in this area. Cheng et al. (2018) have supported this claim, stating that Chinese students often find it challenging to master the conversion of 3D to 2D. The poor performance can be attributed to the lack of a crucial skill in Engineering Graphics and Design (EGD), which is spatial visualization. Singh-Pillay and Sotsaka (2016), assert that drawing and spatial visualization abilities are essential in Assembly Drawing, as they require mentally manipulating objects and their components in 2D and 3D spaces. Scholars such as Khoza (2018; 2017), Makgato (2016), and Sotsaka (2015, 2019) emphasize the importance of spatial visualization skills in EGD.

According to Mlambo et al. (2023), spatial visualization skill involves the ability to visualize objects that are not physically present. Khoza (2013) further explains that in EGD, students are expected to imagine the missing parts, highlighting the significance of spatial visualization. Nelavai and Ramesh (2020) makes a similar claim, stating that essential abilities for mechanical drawing include recognizing and visualizing parts, as well as understanding different perspectives of an object depicted in the drawing. To achieve this, students must be able to think and reason visually in order to connect with Assembly Drawing. The Department of Basic Education (DBE) (2022) also expressed concern about poor performance in Assembly Drawing, citing a lack of spatial visualization skills among learners as the main reason for their inability to draw Assembly Drawings correctly.

In addition to spatial visualization, a background in drawing also plays a significant role in understanding Assembly Drawing. Students who have studied EGD in high school have a higher chance of succeeding in Assembly Drawing compared to those who only start drawing in higher education institutions. Moreover, it has been observed that many students struggle with technical subjects because they do not receive enough practice in high school (T. Mtshali et al., 2019; Reddy, 2017).

### ***Technology to Improve Spatial Visualization***

It has been noted that spatial visualization develops over time with increased exposure to the content. However, one effective way to expedite the development of this skill is through the use of technology. The use of technology is supported by Mlambo (2023) and Mlambo et al. (2023), who suggest that utilizing tools such as AutoCAD software, accessing educational videos on platforms like YouTube, or even incorporating physical models can aid in the development of spatial ability in students. Another technology that has shown promise in enhancing students' spatial ability is mobile augmented reality. A study conducted by Cheng et al. (2018) in China revealed that students who were taught using mobile augmented reality performed exceptionally well compared to their peers. Similarly, Rikza et al. (2024) argue that teaching spatial ability solely through traditional methods, such as pencil and paper, is challenging, making technology an invaluable tool. Mlambo et al. (2023) further

emphasize that integrating information and communication technology (ICT) into teaching and learning can help students grasp abstract concepts by connecting them to concrete examples. Many scholars also highlight the significance of technology in the teaching and learning of architectural design (AD). Kok and Bayaga (2019) found that their experimental research showed a significant difference in favor of the group taught with 3D-CAD. Likewise, Eteli and Eniekenemi (2016) observed that students who learned interior design (ID) with AutoCAD outperformed their peers taught through traditional lecture methods. This underscores the potential of technology in enhancing spatial visualization in AD education. To emphasize the importance of technology in teaching and learning AD, Cheng et al. (2018) state that the traditional teaching methods fail to stimulate students' spatial imagination capabilities. Essentially, this implies that in order to stimulate students' spatial abilities, they should be taught using the latest technological advancements.

### ***Lack of Relevant Qualifications***

The poor performance of students in certain sections of a module has been a persistent issue, with various factors contributing to it. For instance, in Mathematics, students are struggling with Euclidean Geometry, while in EGD, they are performing poorly in Isometric Drawing (ID) and Assembly Drawing (AD). This study aims to investigate the reasons behind this poor performance. According to DBE (2022), the poor performance in AD starts in high school, indicating that learners are already struggling with this subject. This can be attributed to teachers who lack the necessary qualifications to teach. Mtshali (2019) supports this notion, stating that the challenges of teaching practical skills in technical subjects arise from lecturers' insufficient subject knowledge, inadequate teaching materials, and lack of skills, resulting in poor outcomes.

The concern over teachers without relevant qualifications is also raised by Sotsaka (2015), who found that out of 13 teachers interviewed, only 6 had a teaching qualification in EGD. This demonstrates that there are teachers instructing EGD without proper training. It is evident that the poor performance of students in AD can be traced back to underqualified teachers. Sa'ad et al. (2014) further emphasize that inadequate qualification of teachers is a significant factor contributing to students' poor performance. This highlights the crucial role played by qualified teachers in ensuring quality outcomes. Ashraf et al. (2015) also support this idea, stating that qualified teachers are essential for effective schools. They argue that the appointment of underqualified teachers who lack the ability to effectively manage the teaching and learning process leads to poor student performance.

To uncover the factors contributing to the poor performance in teaching and learning of AD, Mtshali (2019) suggests that lecturers should guide students with positive attitudes to enhance their skills and competence in ED. Similarly, scholars like Ashraf et al. (2015) and Sa'ad et al. (2014) have identified negative attitudes from both students and lecturers towards specific sections as factors contributing to poor performance. Therefore, developing a positive attitude towards these sections can potentially improve performance (Kaya & Erdem, 2021).

### **Theoretical Framework**

The Pedagogical Content Knowledge (PCK) framework developed by Shulman (1987) was utilized in this study. According to Shulman (1987), PCK refers to the knowledge that connects content with teachability. The objective of this study is to

examine the factors contributing to poor performance in Engineering Drawing (ED). Previous literature has indicated that one of the contributing factors is the insufficient content and pedagogical knowledge of lecturers. In simpler terms, lecturers lack the knowledge of how to effectively teach the content of ED due to their limited background in Engineering Graphics and Design (EGD), as stated by Mtshali (2019). Therefore, this framework was considered relevant. PCK is a concept that encompasses content knowledge (CK) and pedagogical knowledge (PK), which together form an effective PCK. For the purpose of this study, only CK and PK were employed to help achieve the study's objectives. These constructs were utilized to gather information from the lecturers through semi-structured interviews, in order to assess their approach to teaching ED.

To assess students' level of spatial skills and explore how spatial visualization skills can be enhanced, this study also incorporated the theory of perception and imagery developed by Piaget (1971). Piaget identified four stages of perception: the sensory-motor period, pre-operations, concrete operations, and formal operations. Piaget (1971) proposed that intelligence evolves as children grow, and these stages assist in their cognitive development as they progress.

According to Piaget (1971), during the sensory-motor stage, the children in the sample exhibited a fully egocentric worldview, which persisted until the second stage. At the third stage, children were capable of reversible mental acts, but only with actual, physical objects (Piaget, 1971). In the final stage of formal operations, children were able to take the results of these concrete operations and formulate hypotheses about their logical relationships. This type of thinking is akin to the "scientific method" and is referred to as abstract reasoning. Children were also able to classify, order, and reverse mental operations (Piaget, 1971). The participants in this study are in the final stage, indicating that they are capable of performing ordered and reversed mental operations, which should aid them in visualizing the process of converting 3-D to 2D as it pertains to ED. This framework was employed to determine the level of spatial visualization among students with the assistance of the PSVT.

## METHOD

For the purpose of this study, a pragmatic paradigm was employed as it utilized a mixed approach. It is recognized that employing a mixed method "provides the optimal opportunity to address research questions by capitalizing on the strengths of both methods while also compensating for their respective weaknesses" (Dawadi et al., 2021). Additionally, this study adopted a case study research design, which is considered a robust research method, particularly when a comprehensive and in-depth investigation is required (Tetnowski, 2015). Tetnowski (2015) further highlights that by incorporating both quantitative and qualitative data, a case study helps elucidate a phenomenon's process and outcome through thorough observation.

### Sampling and Participants

This study utilized purposive sampling to select 4 lecturers (as displayed in Table 1) and 45 N3 students studying Engineering Drawing. These particular students were the only ones enrolled in the N3 ED program, as the focus of this study was on N3 students. The selection of 4 lecturers was based on the fact that they were the sole instructors teaching N3 ED. According to Taherdoost (2016), purposive sampling involves choosing participants based on specific characteristics they possess. This method allows for the selection of a specific sample that aligns with the research's

areas of interest. Roestenburg et al. (2021) state that this type of sampling, also called "critical case" sampling, involves selecting groups or individuals based on particular qualities to gain valuable insights into the phenomena being studied. Therefore, participants were chosen based on the information they possessed (Creswell & Creswell, 2018).

**Table 1.** Lecturers' biography

Name of Lecturer	Gender	Experience	Qualification
Lecturer A	Male	10	PGCE in FET (Technical)
Lecturer B	Male	15	N Dip in Electrical Engineering
Lecturer C	Male	10	N Dip in Civil Engineering
Lecturer D	Female	8	B. Tech in Mech Engineering

Table 1 depicts the gender distribution among lecturers, revealing a notable predominance of males in technical subjects, with three males and one female. Furthermore, the table presents the respective experience and qualifications of the lecturers. This study was conducted in a TVET college located in the uMgungundlovu district, where only four lecturers are responsible for teaching ED. This limited sample size of 4 lecturers justifies the utilization of all available lecturers in the study.

### Selection Criteria

This study utilized both lecturers and students to collect data. A total of 45 N3 students were chosen based on their enrollment in the N3 program and their involvement in ED. Therefore, purposive sampling was employed to specifically target individuals with these specified characteristics. The lecturers were selected based on their teaching of ED N3. As seen in Table 1, all the selected lecturers possess backgrounds in engineering, which qualifies them to teach ED.

### Data Collection and Analysis

A mixed research methodology was employed in this study. The Purdue Spatial Visualization Test (PSVT) and semi-structured interviews were utilized to collect data. The PSVT, developed by Bodner and Guay (1997), was used to assess spatial abilities. On the other hand, semi-structured interviews were chosen due to their capacity to gather in-depth data through verbal interaction with participants. The PSVT consists of 36 items that measure spatial ability visualization.

After each interview, the data obtained was transcribed and written down, presenting respondents' quotes as they responded to the questions posed. Data transcription involves transforming spoken words into written words to facilitate better analysis. A thematic analysis was conducted to examine the interview data. The study followed the six steps of data analysis as outlined by Braun et al. (2019): (1) Data familiarization; (2) Coding; (3) Theme generation; (4) Theme review; (5) Theme definition; (6) Writing up. Thematic analysis was chosen for its ability to identify patterns in participants' responses and present them in a logical manner.

Statistical Package for Social Sciences (SPSS) was used to analyze the test results from the PSVT. Descriptive statistics, including mean, standard deviation, and mode, were employed to analyze the data. Descriptive statistics are specific methods used to calculate, describe, and summarize collected research data in a logical, meaningful, and efficient manner (Vetter, 2017). Thus, descriptive analysis was chosen for this

study. Additionally, cross-tabulation was performed on the PSVT results to investigate relationships between two aspects.

### Ethical Considerations

Ethics is an essential component of a research study. This means that individuals and animals involved in the study must be treated ethically. Therefore, the researcher obtained ethical clearance from the Durban University of Technology ethics committee to conduct this study. Additionally, a letter from the campus manager of the TVET college was obtained as a gatekeeper's consent to proceed with the study. Upon receiving the participants' informed consent forms, they were informed that participation is voluntary and that they have the right to withdraw from the study at any time. It was also clarified that there would be no financial benefits from participating in the study, and their personal identities would remain anonymous through the use of pseudonyms. All data obtained from the participants will be securely stored in the researcher's locker and will be destroyed after a period of 3 years.

## RESULTS AND DISCUSSION

### Presentation of Data from the PSVT Test

The test was administered as the initial data collection tool to assess students' spatial skills. This test was necessary due to the significant role that spatial visualization plays in comprehending AD, as highlighted by Sotsaka and Singh-Pillay (2020) that fundamental capabilities required for mechanical drawing, such as recognizing and visualizing parts, as well as understanding different perspectives of an object depicted in a drawing, necessitate the ability to think and reason visually. Thus, students' visual thinking and reasoning abilities are crucial for their engagement with AD. The test aimed to address RQ1: What is the level of spatial visualization among N3 Engineering Drawing students? The following tables display students' performance in the test.

### Students Biography

Figure 3 presents the demographic profile of N3 students participating in this study who are enrolled in ED. Out of the total population of 45 students, 31 were male, accounting for 68.89% of the population, while females comprised only 31.11% of the population.

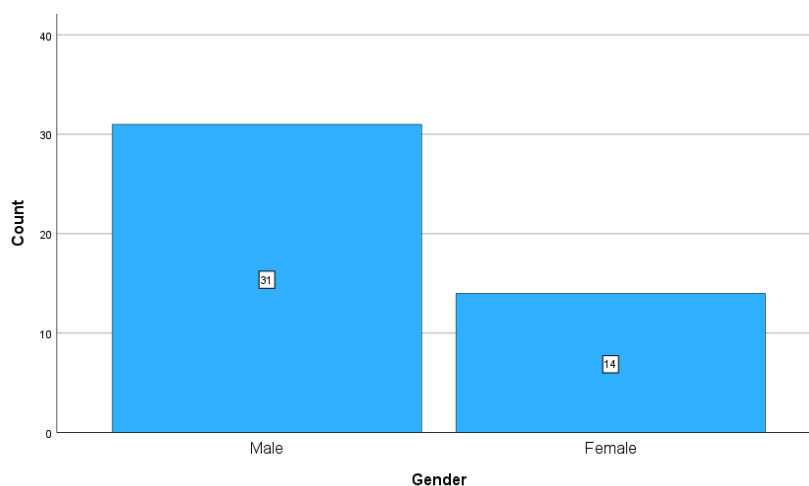
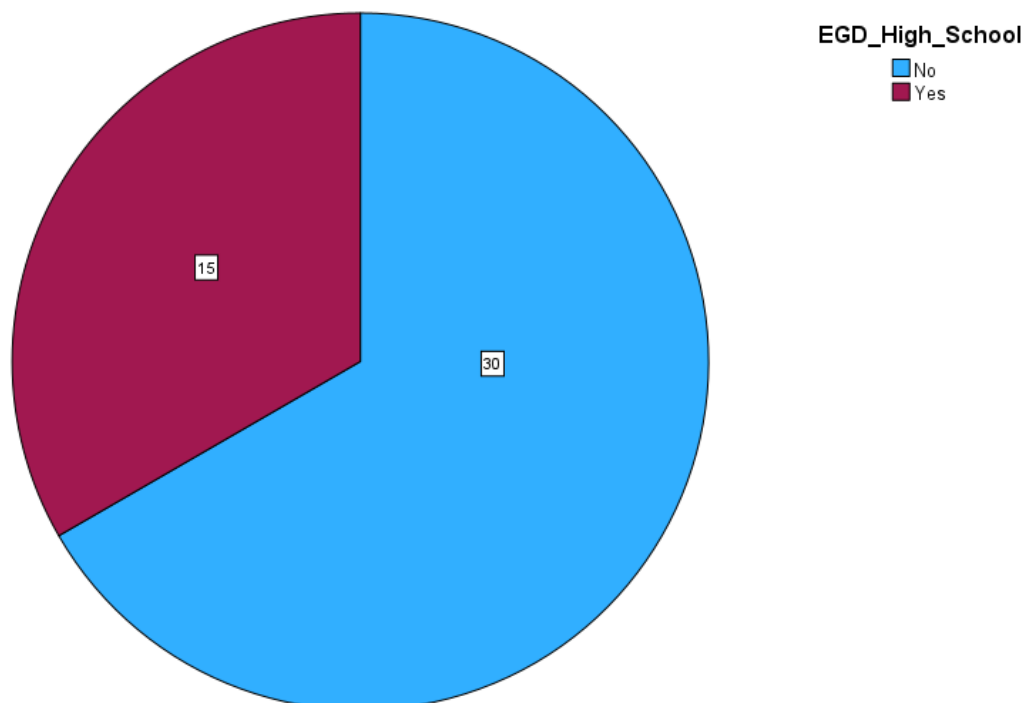

Figure 3. N3 students' biography



### History of EGD in High School

Figure 4 illustrates the percentage of high school students who took EGD. The data reveals that a majority of 66.67% (N=30) of N3 students have a background in EGD from high school. Conversely, only 33.33% (N=15) of students took EGD during their high school years, which is half the number of students who did take EGD.



**Figure 4.** History of EGD in high school

### Students' Performance in the PSVT Test

Table 2 displays the average test score of 16.82 and the standard deviation of 8.389. This indicates that students did not excel in the spatial visualization test, possibly because most of them did not study Engineering Graphics and Design (EGD) in high school, as demonstrated in Table 2. Furthermore, the table reveals that most students achieved a score of 10 out of 36 (27.78%), which falls below the passing threshold of 40% in TVET.

**Table 2.** Descriptive Statistics

N	Valid	Missing
	45	0
Mean	16.82	
Mode	10	
Std. Deviation	8.389	
Minimum	3	
Maximum	36	

Table 3 presents the raw marks out of 36 and the corresponding percentages for the test scores. In order to pass, students were required to obtain a mark greater than 15, which corresponds to achieving a minimum pass mark of 40%. According to Table 3, it is evident that the majority of students, 53.33% (N=24), failed the test as they scored below 15. On the other hand, only 21 students (46.67%) managed to score above 40%, indicating that N3 students are facing challenges in visualizing objects.

**Table 3.** Test scores

Score	N	%
3	1	2.2
6	1	2.2
8	3	6.7
9	2	4.4
10	5	11.1
11	2	4.4
12	4	8.9
13	4	8.9
14	2	4.4
16	2	4.4
17	2	4.4
18	1	2.2
19	2	4.4
20	1	2.2
21	1	2.2
22	2	4.4
25	3	6.7
28	2	4.4
32	2	4.4
33	1	2.2
35	1	2.2
36	1	2.2

**Cross-tabulations**

Below are the cross-tabulations that illustrate the relationship between two variables. Cross-tabulations were conducted to assess whether these variables contribute to poor AD performance among N3 students.

***Cross-tabulation between Test Scores and Doing EGD in High School***

Table 4 presents the correlation between the completion of EGD in high school and the success rate in the PSVT test. The majority of students who did not complete EGD in high school performed poorly in the PSVT test, with a failure rate of 56.67% (N=17). Conversely, only 43.33% (N=13) of students who did not complete EGD in high school managed to pass the test. Additionally, the table demonstrates that 53.33% (N=8) of students who completed EGD in high school successfully passed the PSVT test, while only 46.66% (N=7) did not perform well.

**Table 4.** Cross-tabulation between test scores and EGD in high school

		Test_Scores * EGD_High_School Crosstabulation					
		EGD_High_School				Total	
Test_Scores		No		Yes		N	%
		N	%	N	%		
3		1	3.3	0	0.0	1	2.2
6		0	0.0	1	6.7	1	2.2
8		3	10.0	0	0.0	3	6.7
9		1	3.3	1	6.7	2	4.4

Test_Scores * EGD_High_School Crosstabulation						
EGD_High_School						
	No		Yes		Total	
	N	%	N	%	N	%
10	3	10.0	2	13.3	5	11.1
11	2	6.7	0	0.0	2	4.4
12	3	10.0	1	6.7	4	8.9
13	2	6.7	2	13.3	4	8.9
14	2	6.7	0	0.0	2	4.4
16	2	6.7	0	0.0	2	4.4
17	2	6.7	0	0.0	2	4.4
18	1	3.3	0	0.0	1	2.2
19	1	3.3	1	6.7	2	4.4
20	1	3.3	0	0.0	1	2.2
21	0	0.0	1	6.7	1	2.2
22	1	3.3	1	6.7	2	4.4
25	1	3.3	2	13.3	3	6.7
28	2	6.7	0	0.0	2	4.4
32	1	3.3	1	6.7	2	4.4
33	0	0.0	1	6.7	1	2.2
35	0	0.0	1	6.7	1	2.2
36	1	3.3	0	0.0	1	2.2
<b>Total</b>	<b>30</b>	<b>100.0%</b>	<b>15</b>	<b>100.0</b>	<b>45</b>	<b>100.0</b>

#### Cross-tabulation between Test Scores and Age

Table 5 presents the relationship between age and the passing of the PSVT test. The data in Table 5 indicates that among 5 students aged 16-18 years, only 40% (N=2) passed, while the majority of 60% (N=3) failed. Furthermore, the Table 5 reveals that in the age category of 19-21 years, the majority of 57.14% (N=16) did not pass the test, with only 42.86% (N=12) successfully passing. In the 22-24-year age category, out of 5 students, only 20% (N=1) performed poorly on the test, while the majority, 80% (N=4), managed to pass. Lastly, in the category of 25 and above, there were 7 students, of which only 42.86% (N=3) passed the test, while the majority, 57.14% (N=4), performed poorly.

**Table 5.** Cross-tabulation between test scores and age

Test_Scores * Gender Crosstabulation						
Gender						
	Male		Female		Total	
	N	%	N	%	N	%
Test_Scores 3	0	0.0	1	7.1	1	2.2
6	0	0.0	1	7.1	1	2.2
8	1	3.2	2	14.3	3	6.7
9	1	3.2	1	7.1	2	4.4
10	4	12.9	1	7.1	5	11.1
11	2	6.5	0	0.0	2	4.4
12	3	9.7	1	7.1	4	8.9
13	4	12.9	0	0.0	4	8.9

Test_Scores * Gender Crosstabulation						
	Gender					
	Male		Female		Total	
	N	%	N	%	N	%
14	1	3.2	1	7.1	2	4.4
16	0	0.0	2	14.3	2	4.4
17	1	3.2	1	7.1	2	4.4
18	0	0.0	1	7.1	1	2.2
19	1	3.2	1	7.1	2	4.4
20	1	3.2	0	0.0	1	2.2
21	1	3.2	0	0.0	1	2.2
22	1	3.2	1	7.1	2	4.4
25	3	9.7	0	0.0	3	6.7
28	2	6.5	0	0.0	2	4.4
32	2	6.5	0	0.0	2	4.4
33	1	3.2	0	0.0	1	2.2
35	1	3.2	0	0.0	1	2.2
36	1	3.2	0	0.0	1	2.2
<b>Total</b>	<b>31</b>	<b>100.0</b>	<b>14</b>	<b>100.0</b>	<b>45</b>	<b>100.0</b>

### Discussion of Results from the PSVT Test

The results indicate that a majority of students, 66.67% (N=30), did not study EGD in high school. This lack of exposure to EGD can be seen as a contributing factor to the poor performance of students in AD. Spatial visualization is a skill that can be developed over time, so those who studied EGD in school have a greater chance of passing AD. Marunić and Glažar (2014) support this idea, stating that spatial ability is crucial for effective engineering graphics education and can be improved through instruction and training. Further research has shown that many students struggle with technical subjects after high school due to a lack of practical application experience (T. Mtshali et al., 2019). Therefore, if students begin studying EGD at the college level, they are set up for failure as their spatial skills have not been adequately developed through time and training. Having a background in EGD from high school would help students better understand AD.

The results also revealed that the majority of students, 55.33% (N=24), did not pass the PSVT test, which had a maximum score of 36. This indicates that their spatial visualization skills are very weak, which is why they are performing poorly in AD, as AD requires strong spatial visualization skills. These findings align with a study conducted by Khoza (2017), which found that students struggle with visualization skills and therefore perform poorly on the PSVT. In order to succeed in AD, students need to be able to visualize. Kabouridis (2010) supports this notion, stating that students need to think and reason visually to understand AD. Since these students struggle to visualize, it explains their poor performance in AD. In simple terms, a lack of visualization skills contributes to poor performance in AD.

The poor performance on the test is further supported by the descriptive data in Table 2, which shows a mean score of 16.82 and a standard deviation of 8.389, indicating a low level of spatial visualization skills. The mode score of 10, which represents the most common score among students (27.78%), is also a failure, considering the minimum passing score is 40%. This confirms Giesecke et al.'s (2016)

argument that students need to analyze perspectives and mentally visualize the 3D shape of an object in order to understand AD.

The cross-tabulation between studying EGD in high school and test results reveals a relationship between these two factors. The majority of students (55.67%, N=17) who did not study EGD in high school failed the test, indicating that those without an EGD background performed poorly in N3 AD. This is likely because the class is primarily composed of students without prior EGD background. On the other hand, a majority (53.33%, N=8) of students who studied EGD in high school passed the test.

Another cross-tabulation was conducted between age and test results, as shown in Table 5. The results demonstrate that age is also a contributing factor, as younger students tend to have weaker spatial abilities, which develop over time. This aligns with Piaget's (1971) theory that intelligence changes as a child grows up, and the four stages of cognitive development help children develop their cognitive abilities as they progress through these stages. Therefore, performance on the PSVT test improved as the age groups increased.

### **Presentation and Discussion of Data from Interviews**

Interviews were conducted following the administration of the PSVT test. These interviews served to provide insights for the study's research questions, specifically RQ2: What teaching methods do lecturers employ to teach AD? and RQ3: How do lecturers perceive students' understanding of AD? To enhance the quality of the discussions, themes were derived from the responses provided by the lecturers. The participants' answers to the posed questions are presented below, followed by a detailed analysis of the emerging themes in order to address RQ1, RQ2, and RQ3.

#### ***Theme 1: Lack of EGD Background***

Table 1 illustrates that out of the four interviewed lecturers, none of them possess teaching qualifications except for one who holds a PGCE. However, it should be noted that the PGCE program, which is only one year in duration, may not adequately prepare individuals for teaching a specific subject. These lecturers have obtained National Diplomas in Engineering (Civil, Electrical, and Mechanical), which are not teaching qualifications. Despite this, they have been hired to teach students who also lack teaching qualifications. This could potentially lead to poor performance in AD, as the lecturers have not received proper training in teaching this subject. Mtshali et al. (2019); and Reddy (2017) supports this view by asserting that the difficulty in teaching practical skills in technical subjects arises from lecturers who lack a thorough understanding of the topic, limited teaching resources, and inadequate subject-specific skills, which ultimately result in poor academic outcomes. Sotsaka (2015) also points out the issue of teachers without relevant qualifications, revealing that out of the 13 teachers interviewed, only 6 possessed a teaching qualification in EGD. This indicates that there are teachers instructing EGD without proper training in teaching methods. Similarly, Ashraf et al. (2015) emphasize the critical role of qualified teachers in ensuring effective schools, stating that the appointment of underqualified teachers who lack the necessary skills to facilitate the teaching and learning process effectively is reflected in poor student performance. It is concerning that individuals who have not studied EGD at school are entrusted with teaching it and are expected to achieve satisfactory results (Marunić & Glažar, 2013). This can be identified as one of the contributing factors to the low academic performance.

### **Theme 2: Strong Understanding of AD**

During the interviews, the lecturers were asked to explain their understanding of Assembly Drawing (AD), and it was evident that they had a comprehensive grasp of the concept. Here are their responses:

- Lecturer A: *"Assembly drawing involves the process of assembling different components to create a mechanical device or part."*
- Lecturer B: *"Assembly Drawing focuses on the assembly of various mechanical parts, which is why it was previously known as Mechanical Drawing."*
- Lecturer C: *"Assembly Drawing entails the process of assembling different mechanical parts."*

The responses provided by the lecturers demonstrate their clear understanding of AD. This understanding can greatly benefit students in comprehending the subject matter. Moreover, the lecturers' comprehension aligns with the information presented in the literature. According to Singh-Pillay and Sotsaka (2016), AD refers to the presentation of machine parts in their respective working positions. These drawings are categorized as design assembly drawings, working assembly drawings, sub-assembly drawings, or installation assembly. Additionally, Leeuwen and Plooy (2012) further define AD as the combination of two or more individual components, with these multiple-component devices forming individually designed parts that fit together to create a functional unit. Essentially, the lecturers possess a thorough understanding of AD, which can positively impact their ability to teach the subject effectively.

### **Theme 3: Importance of Visualization Skill**

Another question that was asked inquired about the crucial skill that students should possess in order to understand AD. The lecturers emphasized the significance of spatial visualization skills, as evident from their responses:

*"Lecturer D emphasized that students must develop their visualization skills to envision how the components will appear once assembled. Without this skill, it becomes impossible for students to carry out AD accurately."*

*"Lecturer C stated that visualization skills are essential, along with the ability to determine which parts should be sectioned off since some components are cut apart."*

*"Lecturer B emphasized the importance of being able to visualize how the different parts will connect before drawing them."*

*"Lecturer A highlighted the significance of visualization skills, explaining that AD revolves around assembling various machine components. Hence, students need to know how to visualize."*

The responses provided by the lecturers above clearly underscore the importance of spatial visualization skills for students to gain a better understanding of AD. Insufficient spatial visualization abilities can result in poor performance in AD. Narayana (2019) support the significance of spatial visualization skills, and Singh-Pillay and Sotsaka (2016) posit that AD requires spatial visualization ability, visualization skills, and drawing skills, as it involves mentally manipulating objects and their parts in both 2D and 3D spaces. Kabouridis (2010) also echoes this assertion, emphasizing the essential abilities necessary for detailed mechanical drawing, including the capacity to identify and visualize parts and comprehend various perspectives of an object as depicted in the drawing. Students must engage in visual

thinking and reasoning to effectively interact with AD. Put simply, students must be capable of analyzing multiple perspectives of a particular object and forming an accurate mental image of it. Ultimately, poor performance by students can often be attributed to a lack of spatial visualization skills.

#### ***Theme 4: Negative Attitude by Students and Lecturers***

Another question raised was regarding students' enjoyment of AD. Here is how the lecturers responded to the question:

Lecturer A: *"Most students do not enjoy doing this section as they find it challenging to visualize a complete assembly in their minds before drawing it."*

Lecturer B: *"No, they do not. In my 15 years of experience, I have observed students scoring lower marks."*

Lecturer C: *"They don't enjoy it. They find this section very difficult."*

Lecturer D: *"Most students do not enjoy this section, claiming that it is difficult to put different parts together and hatch them afterwards."*

The above quotes illustrate that students have a negative attitude towards AD, which consequently leads to poor performance. This can be attributed to students lacking spatial visualization skills, which have been mentioned earlier as a crucial skill. The lecturers also demonstrated negative attitudes towards teaching AD.

Lecturer B: *"I don't enjoy teaching this section because as a lecturer, it is challenging to watch students clueless about something you are teaching."*

Lecturer C: *"A little bit. This chapter is very difficult to teach."*

This shows that not only students but also lecturers have a negative attitude towards AD, which is a recipe for disaster. If both parties (students and lecturers) have poor attitudes, students will continue to perform poorly in AD. To enhance students' skills, abilities, and competence in AD, lecturers need to guide them with positive attitudes and values. Negative attitudes are associated with poor performance (Baidoo-Anu, 2018; Kahveci, 2023). Essentially, approaching AD with a positive attitude will yield positive results (Ankiewicz, 2019).

#### ***Theme 5: Infuse Technology to Assist Students***

The lecturers were asked how they teach AD and what could be done to assist students in understanding AD better. Below are the responses from the lecturers:

*"I use models and expose students to YouTube videos so that they can see practical examples of machine parts. I also encourage them to practice more, as engagement in AD helps develop visualization skills."* – Lecturer A

*"I also use models, AutoCAD, and YouTube."* – Lecturer B

*"Software like AutoCAD is very useful. Models are also helpful if you don't have access to software."* – Lecturer C

*"Using software like Sketchup, AutoCAD, and models will help students develop the crucial skill of visualization."* – Lecturer D

From the above responses, it is clear that lecturers believe technology can be used to teach AD so that students can understand it better. This is because technology has been observed to assist in developing spatial visualization skills, which many N3 students seem to lack. Mtshali et al. (2019) supports this notion, stating that some lecturers use outdated materials due to a lack of access to AutoCAD, where they could create their own materials. The effectiveness of AutoCAD in simplifying abstract

concepts and improving spatial visualization has also been emphasized by Mlambo (2023).

## CONCLUSION

Based on the findings, it can be concluded that the spatial visualization skills of N3 students are very low, as most of them performed poorly in the administered PSVT test. Therefore, it can be inferred that a lack of spatial visualization is a contributing factor to poor performance in AD. The students' lack of background in Engineering Graphics and Design (EGD) from high school has a correlation with their poor performance on the PSVT test. Hence, it can be concluded that the absence of an EGD background from high school contributes to inadequate performance in AD. Consequently, the TVET admission policy should be revised to only admit students who have taken EGD in high school.

Furthermore, the findings indicate that students and lecturers have a negative attitude towards the learning and teaching of AD, respectively. As a result, it can be deduced that negative attitudes towards AD contribute to poor performance in the subject. Moreover, based on the findings, it can be concluded that N3 lecturers are not adequately trained to teach AD, as most of them lack teaching qualifications and possess solely Engineering qualifications. Therefore, the lack of relevant teaching qualifications in the field of drawing among lecturers contributes to poor performance in the teaching and learning of AD among N3 students.

## RECOMMENDATIONS

From the findings, it is evident that students have poor spatial visualization skills, which contributes to their poor performance in AD. Therefore, this study recommends that lecturers incorporate technologies such as AutoCAD and YouTube, as well as models, in their everyday teaching. These resources have been found to assist in improving spatial visualization skills.

The findings also revealed that the lecturers who teach N3 Engineering Drawing have not received any training in teaching. They only possess engineering qualifications, which is seen as a factor contributing to poor performance in AD. Based on this, the study recommends that all lecturers should have teaching qualifications when they are hired. Engineering qualifications alone do not equip them with the necessary teaching skills. Furthermore, the teaching qualifications should be relevant to the module they are assigned to teach.

Furthermore, it was evident from the findings that most students who performed poorly in the PSVT did not study EGD in high school. Therefore, this study further recommends that the admission criteria should be amended to only admit students who have studied EGD in high school. The findings showed that students who did not study EGD in high school have poor spatial visualization skills, as indicated by their poor performance in the PSVT test.

## Limitations and Future Research

Despite presenting interesting findings, this study has a few limitations worth noting. The study was conducted at uMgungundlovu TVET College in Pietermaritzburg, and therefore, the results may not be generalizable to a wider South African context. Additionally, the study only used the PSVT test to assess students. For future research, involving students through verbal engagement, such as interviews, is recommended to gather their in-depth views on the difficulties they face



in AD. Furthermore, since the study only involved four lecturers, which is the maximum number of ED lecturers at uMgungundlovu TVET College, future research should include other AD lecturers from different TVET colleges to obtain results that can be generalized.

#### **Author Contributions**

All authors have sufficiently contributed to the study and agreed with the results and conclusions.

#### **Funding Information**

No specific grant or funding was provided for this study.

#### **Conflict of Interests**

The researchers declare no conflict of interests.

#### **REFERENCES**

- Ankiewicz, P. (2019). Perceptions and attitudes of pupils towards technology: In search of a rigorous theoretical framework. *International Journal of Technology and Design Education*, 29(1), 37-56. <https://doi.org/10.1007/s10798-017-9434-z>
- Ashraf, I., Ashraf, F., Saeed, I., Gulzar, H., Shah, K., Azhar, N., Bukhari, S. R., Ilyas, T., & Anam, W. (2015). Reasons for Low Performance of Teachers: A Study of Government Schools operating in Bahawalpur City, Pakistan. *International Journal of Academic Research in Progressive Education and Development*, 4(2), Pages 105-117. <https://doi.org/10.6007/IJARPED/v4-i2/1764>
- Badenhorst, J. W., & Radile, R. S. (2018). Poor Performance at TVET Colleges: Conceptualising a Distributed Instructional Leadership Approach as a Solution. *Africa Education Review*, 15(3), 91-112. <https://doi.org/10.1080/18146627.2017.1352452>
- Baidoo-Anu, D. (2018). Students and Teachers Attitudes Responsible for Poor Academic Performance of Junior High School Students. *Asian Journal of Education and Social Studies*, 2(2), 1-8. <https://doi.org/10.9734/AJESS/2018/40174>
- Bodner, G. M., & Guay, R. B. (1997). The Purdue Visualization of Rotations Test. *The Chemical Educator*, 2(4), 1-17. <https://doi.org/10.1007/s00897970138a>
- Braun, V., Clarke, V., Hayfield, N., & Terry, G. (2019). Thematic Analysis. In P. Liamputtong (Ed.), *Handbook of Research Methods in Health Social Sciences* (pp. 843-860). Springer Singapore. [https://doi.org/10.1007/978-981-10-5251-4\\_103](https://doi.org/10.1007/978-981-10-5251-4_103)
- Cheng, J., Wang, Y., Tjondronegoro, D., & Song, W. (2018). Construction of Interactive Teaching System for Course of Mechanical Drawing Based on Mobile Augmented Reality Technology. *International Journal of Emerging Technologies in Learning (ijET)*, 13(02), 126. <https://doi.org/10.3991/ijet.v13i02.7847>
- Creswell, J. W., & Creswell, J. D. (2018). *Research Design: Qualitative, Quantitative, and Mixed Methods Approaches*. SAGE Publications.
- Dawadi, S., Shrestha, S., & Giri, R. A. (2021). Mixed-Methods Research: A Discussion on its Types, Challenges, and Criticisms. *Journal of Practical Studies in Education*, 2(2), 25-36. <https://doi.org/10.46809/jpse.v2i2.20>
- DBE. (2011). *Curriculum and assessment policy statement: Grades 10-12 Engineering Graphics and Design*. Department of Basic Education Petoria.
- DBE. (2022). *National Senior Certificate. Diagnostic report part 3: Technical subjects*. Government printers. Department of Basic Education Petoria.

- Diraso, D., Manabete, S., Amalo, K., Mbudai, Y., Suleiman, A., & Jaoji, A. (2013). Evaluation of students' performance in technical and engineering drawing towards an effective career choice in engineering and technical and vocational education. *International Journal of Educational Research and Development*, 2(4), 89–97.
- Eteli, I., & Eniekenemi, E. (2016). Effect of Autocad Software In Teaching Isometric And Oblique Drawing Among Female Students In Federal Science Technical College Tungbo, Bayelsa State. *International Journal of Education and Evaluation*, 2(2), 25–31.
- Giesecke, F. E., Mitchell, A., Spencer, H. C., Hill, I. L., Dygdon, J. T., Novak, J. E., Loving, R. O., Lockhart, S., & Johnson, C. (2016). *Technical Drawing with Engineering Graphics*. Pearson Education.
- Kabouridis, G. (2010). An innovative approach to face the first-year mechanical engineering students' conceptual difficulties in engineering design. *1st WIETE Annual Conference on Engineering and Technology Education*. <https://www.semanticscholar.org/paper/An-innovative-approach-to-face-the-first-year-in-Kabouridis/31df138a74cf2ecb40fe82b3efa284e812f14335>
- Kahveci, H. (2023). The positive and negative effects of teacher attitudes and behaviors on student progress. *Journal of Pedagogical Research*, 7(1), 290–306. <https://doi.org/10.33902/JPR.202319128>
- Kaya, M., & Erdem, C. (2021). Students' Well-Being and Academic Achievement: A Meta-Analysis Study. *Child Indicators Research*, 14(5), 1743–1767. <https://doi.org/10.1007/s12187-021-09821-4>
- Khoza, S. (2018). *A teaching strategy for sectional drawing concept: A Case of pre-service teachers in a Johannesburg University, South Africa*. 9655–9661. <https://doi.org/10.21125/inted.2018.2419>
- Khoza, S. D. (2017). Spatial skill's development and line-work improvement in learning the Design process in a Technology Subject at a Johannesburg University. *International Journal of Engineering and Technology*, 9(4), 3020–3027. <https://doi.org/10.21817/ijet/2017/v9i4/170904106>
- Kok, P. J., & Bayaga, A. (2019). Enhancing Graphic Communication and Design Student Teachers' Spatial Visualisation Skills through 3D Solid Computer Modelling. *African Journal of Research in Mathematics, Science and Technology Education*, 23(1), 52–63. <https://doi.org/10.1080/18117295.2019.1587249>
- Leeuwen, J. V., & Plooy, D. D. (2012). *Engineering Graphics and Design Textbook: NCAPS. Grade 11*. Allcopy Publishers.
- Makgato, M. (2016). Difficulties of Student Teachers in the Engineering Graphics and Design Course at a South African University: Snapshot on Sectional Drawing. *EURASIA Journal of Mathematics, Science and Technology Education*, 12(4). <https://doi.org/10.12973/eurasia.2016.1220a>
- Marunić, G., & Glažar, V. (2013). Spatial ability through engineering graphics education. *International Journal of Technology and Design Education*, 23(3), 703–715. <https://doi.org/10.1007/s10798-012-9211-y>
- Marunić, G., & Glažar, V. (2014). Improvement and assessment of spatial ability in engineering education. *Engineering Review*, 34(2), 139–150.
- Mlambo, P. B. (2023). Information and Communications Technology in Engineering Graphics and Design Classrooms: A post COVID-19 era. *Jurnal Penelitian Dan*

- Pengkajian Ilmu Pendidikan: E-Saintika*, 7(2), 160–175.  
<https://doi.org/10.36312/esaintika.v7i2.1321>
- Mlambo, P. B., Maeko, M. S. A., & Khoza, S. D. (2023). Teachers' Readiness towards the Integration of Information and Communications Technology in Teaching and Learning of Engineering Graphics and Design in KwaZulu-Natal. *Research in Social Sciences and Technology*, 8(3), 176–195.  
<https://doi.org/10.46303/ressat.2023.26>
- Mtshali, T. I., & Singh-Pillay, A. (2023). Pedagogical Capital Strategies for Civil Technology Skills-Based Activities. *International Journal of Learning, Teaching and Educational Research*, 22(5), 389–409. <https://doi.org/10.26803/ijlter.22.5.20>
- Mtshali, T., Sylvia, R., & Manto. (2019). Civil Technology Teacher's Environmental Knowledge in Promoting Active Learning During Practical Lessons: A South African Perspective. *Online Journal for TVET Practitioners*, 4(1), 1–9.  
<https://doi.org/10.30880/ojtp.00.00.0000.00.0000>
- Narayana, K. L. (2019). *Machine Drawing* (Sixth edition). New Age International Publishers.
- Nelavai, N., & Ramesh, S. (2020). An Insight into the challenges faced by First Year Engineering Students: Poor Foundational Knowledge. *Procedia Computer Science*, 172, 823–830. <https://doi.org/10.1016/j.procs.2020.05.118>
- Piaget, J. (1971). The theory of stages in cognitive development. In *Measurement and Piaget* (pp. ix, 283–ix, 283). McGraw-Hill.
- Ramatsetse, B., Daniyan, I., Mporofu, K., & Makinde, O. (2023). State of the art applications of engineering graphics and design to enhance innovative product design: A systematic review. *Procedia CIRP*, 119, 699–709.  
<https://doi.org/10.1016/j.procir.2023.05.006>
- Reddy, C. (2017). Environmental education in teacher education: A viewpoint exploring options in South Africa. *Southern African Journal of Environmental Education*, 33(1), 117. <https://doi.org/10.4314/sajee.v.33i1.9>
- Rikza, Johar, R., & Elizar, E. (2024). Students responses in using video tutorials to test students' spatial ability. 020030. <https://doi.org/10.1063/5.0184720>
- Roostenburg, W. J. H., Strydom, H., & Fouché, C. B. (2021). *Research at Grass Roots: For the Social Sciences and Human Services Professions*. Van Schaik Publishers.
- Sa'ad, T. U., Adamu, A., & M. Sadiq, A. (2014). The Causes of Poor Performance in Mathematics among Public Senior Secondary School Students in Azare Metropolis of Bauchi State, Nigeria. *IOSR Journal of Research & Method in Education (IOSRJME)*, 4(6), 32–40. <https://doi.org/10.9790/7388-04633240>
- Šafhalter, A., Glodež, S., Šorgo, A., & Ploj Virtič, M. (2022). Development of spatial thinking abilities in engineering 3D modeling course aimed at lower secondary students. *International Journal of Technology and Design Education*, 32(1), 167–184.  
<https://doi.org/10.1007/s10798-020-09597-8>
- Shulman, L. (1987). Knowledge and Teaching: Foundations of the New Reform. *Harvard Educational Review*, 57(1), 1–23.  
<https://doi.org/10.17763/haer.57.1.j463w79r56455411>
- Singh-Pillay, A., & Sotsaka, D. S. (2016). Engineering Graphics and Design Teachers' Understanding and Teaching of Assembly Drawing. *EURASIA Journal of Mathematics, Science and Technology Education*, 13(5).  
<https://doi.org/10.12973/eurasia.2017.00668a>

- Sotsaka, D., & Singh-Pillay, A. (2020). Meeting the challenges first year engineering graphic design pre-service teachers encounter when they read and interpret assembly drawing. *Journal of Education*, 80, 72–86. <https://doi.org/10.17159/2520-9868/i80a04>
- Sotsaka, D. T. S. (2015). *An exploration of the interface between Grade 11 Engineering Graphics and Design teachers' understanding of Assembly Drawing and their practice: A case study of the uThukela District, KwaZulu-Natal*. [Thesis, University of KwaZulu-Natal]. <http://hdl.handle.net/10413/13750>
- Sotsaka, D. T. S. (2019). *Unmasking how pre-service engineering graphics and design teachers read and interpret assembly drawing at a university of technology: A case study in Umgungundlovu, KwaZulu-Natal* [Thesis]. University of KwaZulu Natal.
- Taherdoost, H. (2016). Sampling Methods in Research Methodology; How to Choose a Sampling Technique for Research. *SSRN Electronic Journal*. <https://doi.org/10.2139/ssrn.3205035>
- Tetnowski, J. (2015). Qualitative Case Study Research Design. *Perspectives on Fluency and Fluency Disorders*, 25(1), 39–45. <https://doi.org/10.1044/ffd25.1.39>
- Vetter, T. R. (2017). Descriptive Statistics: Reporting the Answers to the 5 Basic Questions of Who, What, Why, When, Where, and a Sixth, So What? *Anesthesia & Analgesia*, 125(5), 1797–1802. <https://doi.org/10.1213/ANE.0000000000002471>